

## VCN External Wall Fan

### Available Sizes:

- 125mm
- 150mm
- 200mm



### Product Description

The VCN is designed as an exterior mounted exhaust fan. The centrifugal motor is protected within the weather proof metal body.

The VCN range features IPX4 protection and an operating temperature of up to 55 degrees C. It can perform well with long lengths of duct.

Size	125	150	200
D(mm)	124	149	199
B(mm)	260	300	300
H(mm)	355	400	400
L(mm)	138	138.2	138.2

### Specifications:

	125	150	200
Model			
Capacity m <sup>3</sup> /hr	390	600	710
Capacity L/S	108.33	166.67	197.22
Power Used W	75	100	100
Noise Level db(A)	48	58	62

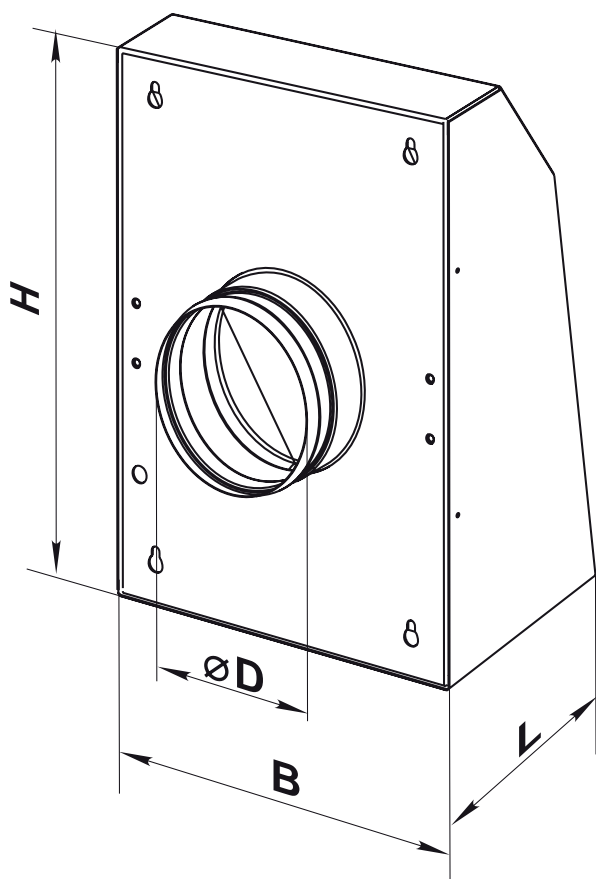

### Features

- Weather Proof
- Good Capacity
- High Performance