

VK Centrifugal Fan

Available Sizes:

100mm
150mm
200mm



White

Product Description

The VK plastic inline fan is a quality inline fan that is normally ducted and may be used for exhaust, air transfer and other applications.

The VK fan is made from high quality durable ABS plastic and is equipped with a waterproof terminal box. The corrosion resistant plastic casing makes the centrifugal fan perfect for installation in humid premises such as bathrooms, kitchens etc.

It is available in three sizes (100mm, 150mm and 200mm) and is long life, continuous rated with a IPX4 rating. The package includes mounting brackets, which make installation easy and convenient.

Features:

- Corrosion resistant plastic
- Waterproof terminal boxes
- Single phase AC motor with dynamic balanced impeller
- Maintenance free ball bearing motor

Fan overall dimensions:

Type	Dimensions [mm]							Mass [kg]
	∅D	∅D1	B	L	L1	L2	L3	
VK 100	100	250	270	230	30	27	30	2,15
VK 125	125	250	270	220	30	27	30	2,2
VK 150	150 / 160	300	310	286	30	30	30	2,6
VK 200	200	340	354	276	30	30	40	4,0
VK 250	250	340	354	265	30	30	40	4,5
VK 315	315	400	414	276	40	55	40	5,1

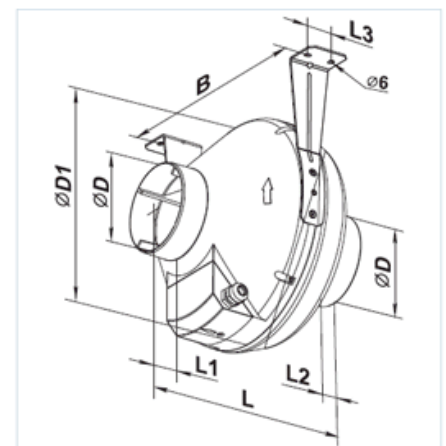

Specifications:

Model	100	150	200
Capacity m ³ /hr	250	460	930
Capacity L/S	69.44	127.78	258.33
Power Used W	80	80	173
Noise Level db(A)	46	48	51